

SSP20 Surge Filter

Creating Systems to Control, Power & Integrate Your Business

Outstanding Features:

- ◆ High performance and long life design
- ◆ 50,000 amps of surge capacity
- ◆ Integral EMI/RFI protection
- ◆ Three stage construction
- ◆ Common and Normal mode protection
- ◆ Dual technology – GDT and MOV
- ◆ LED status monitor



The **SSP20 Surge Filter** is a series hybrid point of use protector that provides the ultimate in protection for sensitive electronic equipment. Applications include PBX, PLC, industrial control systems, broadcast & cellular, fuel dispensing equipment, in short, any equipment requiring protection from transient voltage and surges. Equipment protected by the SSP will not only be protected from destructive damage, but will also benefit from increased reliability, decreased maintenance and longer useful service life.

The SSP20 incorporates several features which make it an ideal choice for the protection of sensitive electronic systems:

- ◆ **Three stage construction** provides the ultimate in reliability and protection.
 - **Stage One** is a high energy current shunt which diverts transient energy away from the protected equipment.
 - **Stage Two** is a bi-directional noise filter that removes both common and differential mode noise. It contains an integral series control element which slows the rise time and limits the magnitude of incoming transients.

- **Stage Three** is a high speed voltage clamp which limits the peak voltage to safe levels.

- ◆ **Dedicated protection elements** for both common mode (line to ground) and normal mode (line to line) protection assure the lowest possible clamping levels no matter what the source of the surge.
- ◆ **Neutral conductor protection** eliminates data errors in sensitive microprocessor and process control circuits.
- ◆ **Dual technology protection elements** provide superior protection over units which rely on only one technology. The high energy handling capabilities of the gas discharge tube and the high speed characteristics of the metal oxide varistor are combined in the SSP20.
- ◆ **All components are mounted on heavy duty 2 ounce FR4 circuit board.** This insures the lowest possible impedance in the surge path.
- ◆ **Internal fusing** protects the SSP20 as well as the connected equipment from overcurrent and ground faults.

CAROLINA PRODUCTS, INC.
CAROLINA PRODUCTS INC

1132 Pro Am Drive
Charlotte, NC 28211

Phone: 704-364-9029
Toll Free: 800-736-4455
Fax: 704-367-1215

E-mail: sales@cpipanel.com
Website: www.cpipanel.com

Monitoring

An on-board indicator light gives the user a clear visual indication of the status of the protector. Long life LED's are used instead of failure prone neon or incandescent lamps.

Enclosure

The SSP20 is available in a DIN rail mountable polycarbonate case (UL94 VO) or in a PCB version for use in Snap-Track applications or custom packaging.

Connections

The tinned bronze, cage clamp terminal strip will accept #22-12 AWG conductors.

Warranty

The SSP20 comes with a full 2 year warranty. Any properly installed unit which fails during the warranty period will be replaced at no charge.

SSP20 Technical Specifications

Maximum input voltage	130 V RMS
Maximum series line current	20 A RMS
Peak surge current (8/20 microsecond)	50,000 amps
Maximum clamping voltage (8/20 uSec @ 200 amps)	340 volts (L-G)
Response time	< 5 nanoseconds
Insertion loss	22dB @ 1 MHz.

To place an order for a CPI SSP20 Surge Filter simply call or email CPI with the model number, quantity desired, purchase order number and the ship to address and CPI will do the rest.

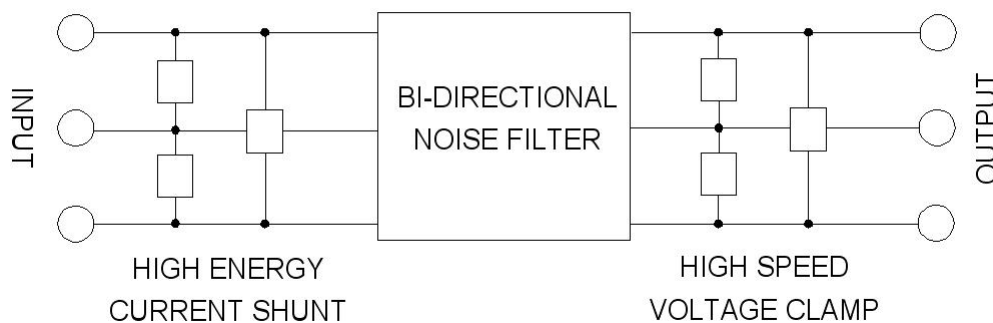

SSP20 Block Diagram

CALL TODAY AND LET CPI BUILD A
SYSTEM TO CONTROL, POWER, &
INTEGRATE YOUR BUSINESS

CPI
CAROLINA PRODUCTS, INC.
CAROLINA PRODUCTS INC

1132 Pro Am Drive
Charlotte, NC 28211

Phone: 704-364-9029
Toll Free: 800-736-4455
Fax: 704-367-1215
E-mail: sales@cpipanel.com
Website: www.cpipanel.com